

INSTRUCTION MANUAL

This manual forms an integral part of the pump and must accompany it until its demolition. The series AMP peristaltic pump is a machine destined to work in industrial areas and as such the instruction manual must form part of the legislative dispositions and the applicable technical standards and does not substitute any installation standard or eventual additional standard.

GENERAL SAFETY WARNING

Pumps are machines that can present dangers due to their operating under pressure and containing numerous moving parts.

- Improper use
- Removing the protections and/or disconnecting the protection device
- The lack of inspections and maintenance

CAN CAUSE SERIOUS DAMAGE OR INJURY

The person in charge of safety should therefore guarantee that

- The pump is transported, installed, put in service, used, maintained and repaired by qualified personnel who should possess:

- Specific training and sufficient experience.
- Knowledge of the technical standards and applicable laws.
- Knowledge of the general national and local safety standards and also of installation.

Any work carried out on the electrical part of the pump should be authorized by the person responsible for safety. Given that the pump is destined to form part of an installation, it is the responsibility of whoever supervises the installation to guarantee absolute safety, adopting the necessary measures of additional protection.

INDEX

	Page
Equipment Identification	01
Cover	02
Index	03
Transport, storage and elevation	04
General safety standards	05
General description	07
Installation	08
Roller pressure adjustment	08
Work conditions	09
Performance curves	10
Checks before starting up the machine	11
Maintenance	11
Removal of the hose – disassembly	12
Installation of the hose – assembly	12
Problems, causes and solutions	13
Diagram of components parts	14
Spare parts code	15
Warranty Statement	17

TRANSPORT, STORAGE and ELEVATION

TRANSPORT

- The pump is protected by a wood packaging.
- The packaging materials are recyclable.

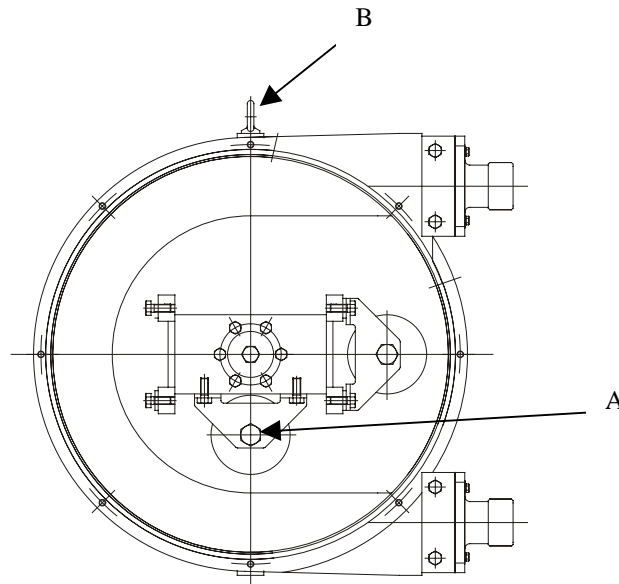
**STORAGE**

- The pump should be in a resting position – refer to figure “A” (The hose should not be compressed)
- Avoid areas open to inclement weather or excessive humidity.
- For storage periods of longer than 60 days, protect the coupling surfaces (clamps, reducers, motors) with adequate anti-oxidant products.
- Spare tubes should be stored in a dry place away from the direct light.

LIFTING

- For the elevation of the pump, it has a eye bolt on the top (See figure B).

GENERAL SAFETY STANDARDS



- Instructions in this manual that may compromise safety standards are identified by this symbol



- Instructions in this manual that may compromise electrical safety are identified by this symbol.

WARNING!

- Instructions in this manual that may compromise the proper operation of the pump are identified with this symbol.



Do not start the pump without first having installed the front cover.

For any operation of the equipment, it is necessary to make certain that the pump is stopped and the electrical supply disconnected.



Changing the hose should be done with the pump stopped.

WARNING!

Do not exceed the nominal design pressure, speed or temperature of the pump, or use the pump for applications other than that originally planned without first consulting the manufacturer.

WARNING!

Cleaning the pipe, including the hose, should be done with fluids compatible with the pump hose and within its maximum recommended temperature.

WARNING!

Do not start the pump without it being properly secured to the floor.



Do not attempt carry out any maintenance operations or dismantle the pump without first making sure that the suction and discharge pipes are not under pressure, and are empty or isolated by proper valving.



The start system of the motor should be provided with a direction inverter, stop-go button and emergency stop button (together with the pump), in such a way that the pump can be operated or the hose changed with total safety.



Peristaltic pumps are positive displacement devices capable of generating high pressures. To prevent possible overload of pressure due to for example: the accidental closure of a valve. It is advisable to fit a safety device such as: a safety valve or other pressure limiting device in the discharge piping.



Check the rotation of the pump, as it is reversible, it could generate pressure in the suction and compromise the safety of the installation. The circulation of the fluid should be in the same direction as the turning direction of the pump as seen from the front cover.



The durability of the hose may vary due to operating conditions, so the possibility of a rupture and subsequent leakage of fluid should be anticipated. The (optional) hose leakage detection probe can be interlocked to stop the pump and/or actuate an automatic valve and/or sound an alarm.

GENERAL DESCRIPTION

PERISTALTIC PUMP

- **Construction of the pump.**

As shown in the figure below, the PeriFlo pump unit is a very simple, robust design with very few moving parts.

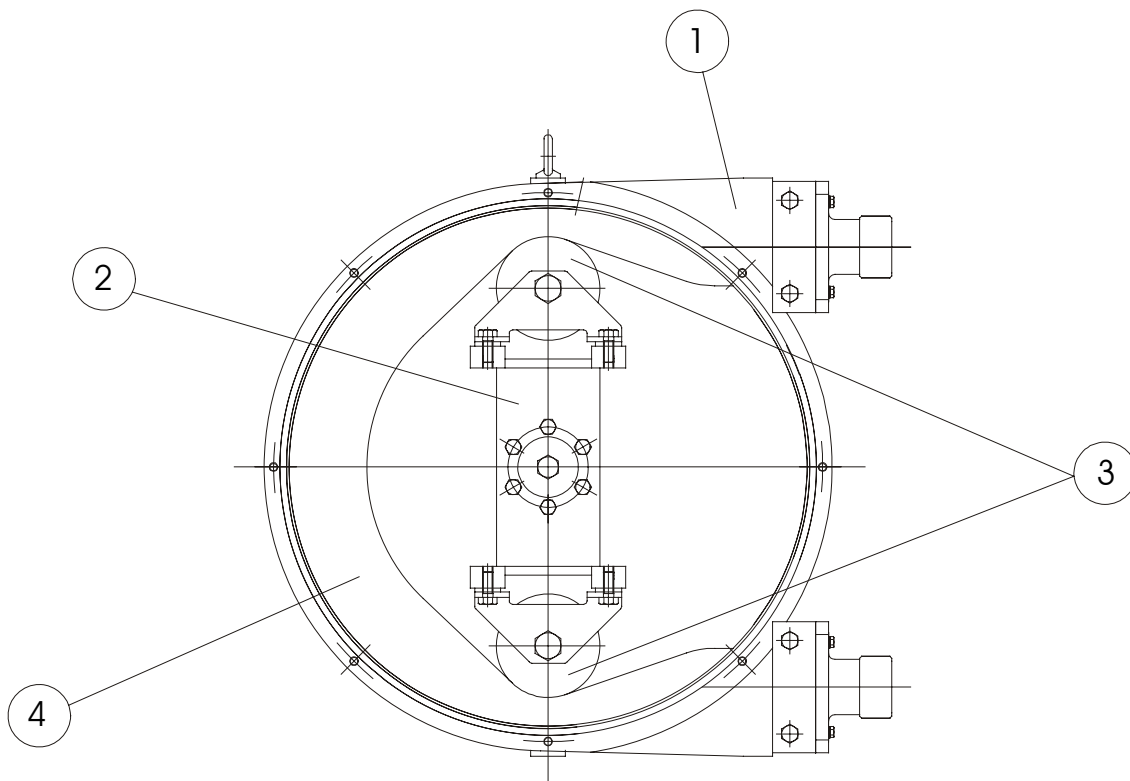

The outer casing (item 1) terminates with 150#ANSI flanged connections. Inside the casing are found the rotor (item 2), completed with two rollers (item 3). As the rotor rotates, the rollers compress the reinforced hose (item 4) generating a pumping action. A change in the direction of rotation will result in a change in direction of the pumped fluid.

INSTALLATION

- Installation should normally be made in a well ventilated area away from heat sources. If it is necessary to place the pump outside, it should be provided with a cover to protect it from sunlight and inclement weather.
- The positioning of the pump should allow easy access for all kinds of maintenance operations. In general, and to facilitate the changing of the hose, it is advisable to use easily removed connectors. There should be a minimum space of approximately 38 inches and 44 inches for Models FMP30 and FMP40 respectively.

Piping – Correct Installation

Suction:

- The pump should be as near as possible to the supply of liquid so that the suction pipe is as short and straight as possible. The suction pipe should be perfectly airtight and made of suitable material so that it does not collapse due to internal vacuum.
 - The minimum diameter should be similar to that of the tubular element.
 - With viscous fluids a larger diameter is recommendable.
(Consult manufacturer or distributor).
 - The pump has automatic suction and does not need an inlet.
- The pump is reversible, so the suction and discharge connections are interchangeable.
(The pump is normally piped in a manner that best adapts to the physical installation)
- It is recommended to use a flexible connection between the fixed piping and the pump in order to reduce the transmission of vibration to the piping,

Discharge:

- To reduce power requirements, use the straightest and shortest piping possible. The diameter should be the same as the nominal diameter of the pump, excepting precise calculations of pipe and system losses.
 - With viscous fluids a bigger diameter is needed. (Consult the manufacturer or distributor).
- Connecting the fixed piping to the pump with a length of flexible pipe facilitates maintenance and avoids vibrations and loads on the pump. Fix the piping firmly.
- The discharge will pulse: To reduce pulsation, it is advisable to install adequate pulsation dampening equipment in the discharge line.. (See accessories.)

ROLLER/SHIM - PRESSURE ADJUSTMENT

FMP-30 (Number of shims of 0,5 mm.)

SPEED - RPM	0-19	20-39	40-59	60-79	80-99
PRESSURE-PSIG					
7,5	1	1	0	0	0
30	1	1	1	1	1
60	2	1	1	1	1
90	2	2	2	1	--
115	3	2	2	--	--

FMP-40 (Number of shims of 1 mm.)

SPEED - RPM	0-19	20-39	40-59	60-79	80-99
PRESSURE-PSIG					
7,5	4	4	4	4	3
30	5	4	4	4	4
60	5	5	5	4	4
90	6	5	5	--	--
115	6	6	--	--	--

WORKING CONDITIONS

MATERIAL	TEMPERATURE MIN (°C)	TEMPERATURE MÁX (°C)	TEMPERATURE MIN. AMBIENT (°C)	PRESSURE MAX PSI
NR	-20	90	-40	115
NBR	-10	80	-40	115
EPDM	-10	90	-40	115
NR-(FD GR)	-10	90	-40	115
NBR-(FD GR)	-10	90	-40	115

PERFORMANCE CURVES

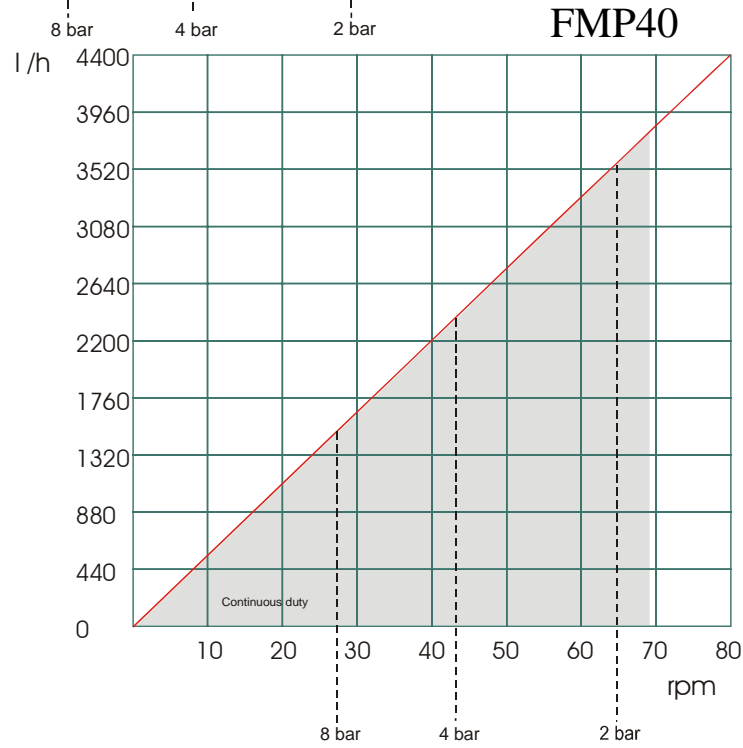
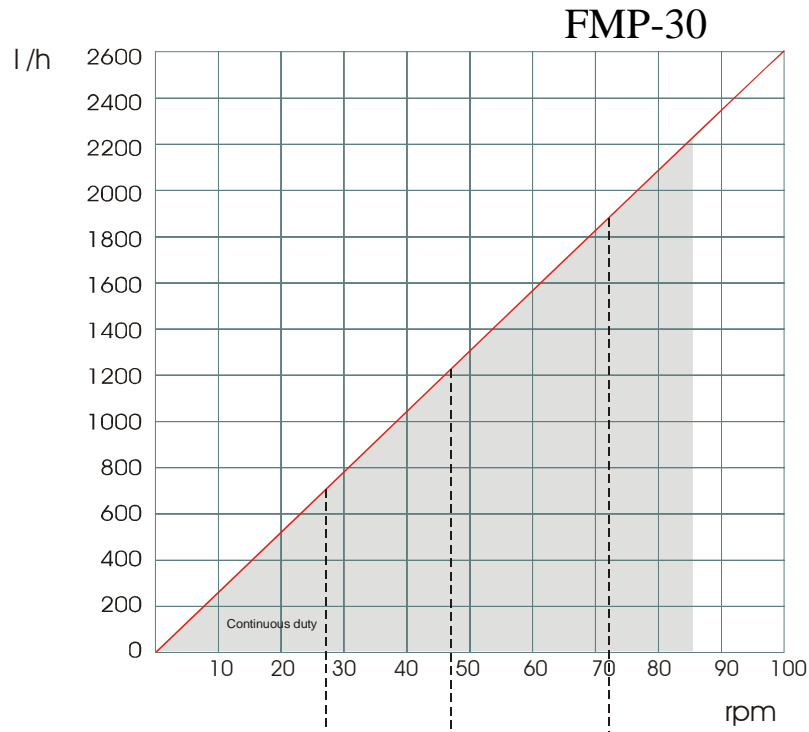

CHECKS BEFORE SWITCHING ON THE PUMP

Check that the pumping equipment has not suffered any damage during transportation or storage, any damage should be notified to the supplier immediately.

Check that the supply voltage is suitable for the motor.

Make sure that the hose is suitable for the fluid to be pumped and will not be chemically affected, and that the temperature of the fluid does not exceed that recommended for the hose.

If the hose is in a resting position, then the pump has come from storage or transportation; it is necessary to install the second roller.

Caution: **Do not switch on the pump without the pump cover being correctly installed.**

Lubrication:

Check that the pump drive, the hose and rollers are correctly greased. The hose and rollers should be lubricated with specially formulated silicon grease that can be obtained from PERIFLO, INC or from the authorised distributor.

Check that the protectors of the moving parts are correctly assembled.

Check that the thermal overload protector corresponds with that of the values on the plate on the motor.

Check that the direction of rotation is the desired one. (rotation test).

Check that the optional electrical components are connected to the control panel and test that they function correctly.

Check that a proper pressure gauge is installed in the discharge. If the application involves a highly viscous fluid, it is recommended that a proper absolute-pressure gauge be installed in the suction line.

Check in predicted working conditions that the values of flow, pressure and absorbed power of the motor correspond to the project.

MAINTENANCE

Any work carried out on the pump must be done when the pump is stationary and disconnected from the electrical supply.

Lubrication

Check that the lubricant level in the gear reducer and/or the variator are correct, and carry out periodic changes of lubricant according to the maintenance manual.

FOLLOW THE LUBRICATION RECOMMENDATIONS OF THE DRIVE MANUFACTURER.

REMOVING OF HOSE - DISASSEMBLY

- Close suction and discharge valves to properly isolate the pump and prevent loss of the product.
- Disconnect and remove the suction and discharge piping.
- Remove the front cover.
- Remove the roller that is not in contact with the hose.
- Replace the front cover (temporarily with only 2 bolts) and rotate the pump 180° until the other roller doesn't contact the hose. (this may be done by bumping the drive)
- Remove the inlet and outlet flange assemblies (items 12 & 14) and the closing rings (item 13)
Note that it is not necessary to disassemble the flange assemblies.
- Remove the hose.

INSTALLING THE HOSE - ASSEMBLY

- Remove the front cover and clean the internal surfaces of the pump body. All contamination should be removed.
- Inspect the rollers and roller bearings to insure continued smooth operation and inspect rotor seals to insure that there is no foreign matter that could impede proper performance.
- Lubricate the internal faces of the pump body where there could be contact with the hose, lubricate the exterior surface of the new hose and lubricate the surface of the rollers with PeriFlo Silicon grease.
- Install the closing ring and flange assembly to one end of the new hose, and install the new hose into the pump.
- Install the closing ring and flange assembly to the other end of the hose.
- Install the flange assemblies the pump body. (compressing the closing ring around the hose)
- Fit the front cover (temporarily with only 2 bolts) and rotate the pump 180° until the installed roller fully contacts the hose.
- Remove the front cover and install the second roller.
- Install the front cover.
- Connect the suction and discharge piping.

PROBLEMS, CAUSES AND SOLUTIONS

PROBLEM	POSSIBLE CAUSE	SOLUCIÓN
Elevated Temperature	<p>Hose with no lubricant Elevated temperature of product Poor or bad suction conditions</p> <p>Excessive pipe tightening Excessive number of shims Excessive pumping speed</p>	<p>Use special PeriFlo Silicon lubricant Reduce pumping temperature Check there are no obstructions Recalculate pipe diameters and lengths Check roller pressure adjustment Confirm the proper number of shims Reduce velocity of pump</p>
Reduction of Capacity/pressure	<p>Suction or discharge valve closed. Hose insufficiently compressed</p> <p>Rupture of the hose (the product leaks to the casing) Partial obstruction of suction piping Insufficient product amount in suction reservoir Insufficient diameter of suction piping Excessive length of suction pipe High viscosity of product</p> <p>Entry of air via the suction connections High pulsation on suction</p>	<p>Open valves Check roller pressure adjustment/shims</p> <p>Replace drive hose</p> <p>Clean piping Fill Reservoir or stop pump Increase pipe diameter/reduce pump speed Shorten suction piping Reduce viscosity Increase suction pipe diameter Confirm that the pump is suitable Tighten connections and accessories Mount pulsation dampening equipment Reconsider application (speed etc.)</p>
Vibrations in pump and piping	<p>The piping is not correctly fitted together Excessive pumping speed</p> <p>Insufficient diameter of piping Bedplate of pump loose Elevated pulsation of pump</p>	<p>Refit piping Reduce the speed of the pump</p> <p>Increase pipe diameter Fix the bedplate firmly Install suction and/or outlet pulsation dampening equipment</p>
Short hose life	<p>Chemical attack</p> <p>High speed of pump High pumping temperature High working pressure</p> <p>Abnormal elevation of temperature Unsuitable lubricant Insufficient quantity of grease Cavitation of the pump</p>	<p>Confirm compatibility of the hose with the pumped fluid and any cleaning fluids Reduce speed of pump Reduce temperature of product Reduce speed of pump Increase diameter of piping Check roller pressure adjustment/shimming Use PERIFLO lubricant Top up lubricant Reconsider suction conditions</p>
Stretching of the hose inside the pump	<p>Insufficient grease High suction pressures (>45 psi) Hose full of sediment Brackets insufficiently tightened</p>	<p>Top up lubricant Reduce suction pressure Clean hose Retighten brackets</p>
The pump does not start	<p>Insufficient starter power Insufficient power from frequency convertor</p> <p>Blockage in the pump</p>	<p>Increase starter power Increase power/boost Check that the voltage is adequate Do not drop below a frequency of 10Hz (confirm this point with the distributor) Start-up will require a minimum of 10 Hz Check there are no obstructions in the pipe</p>

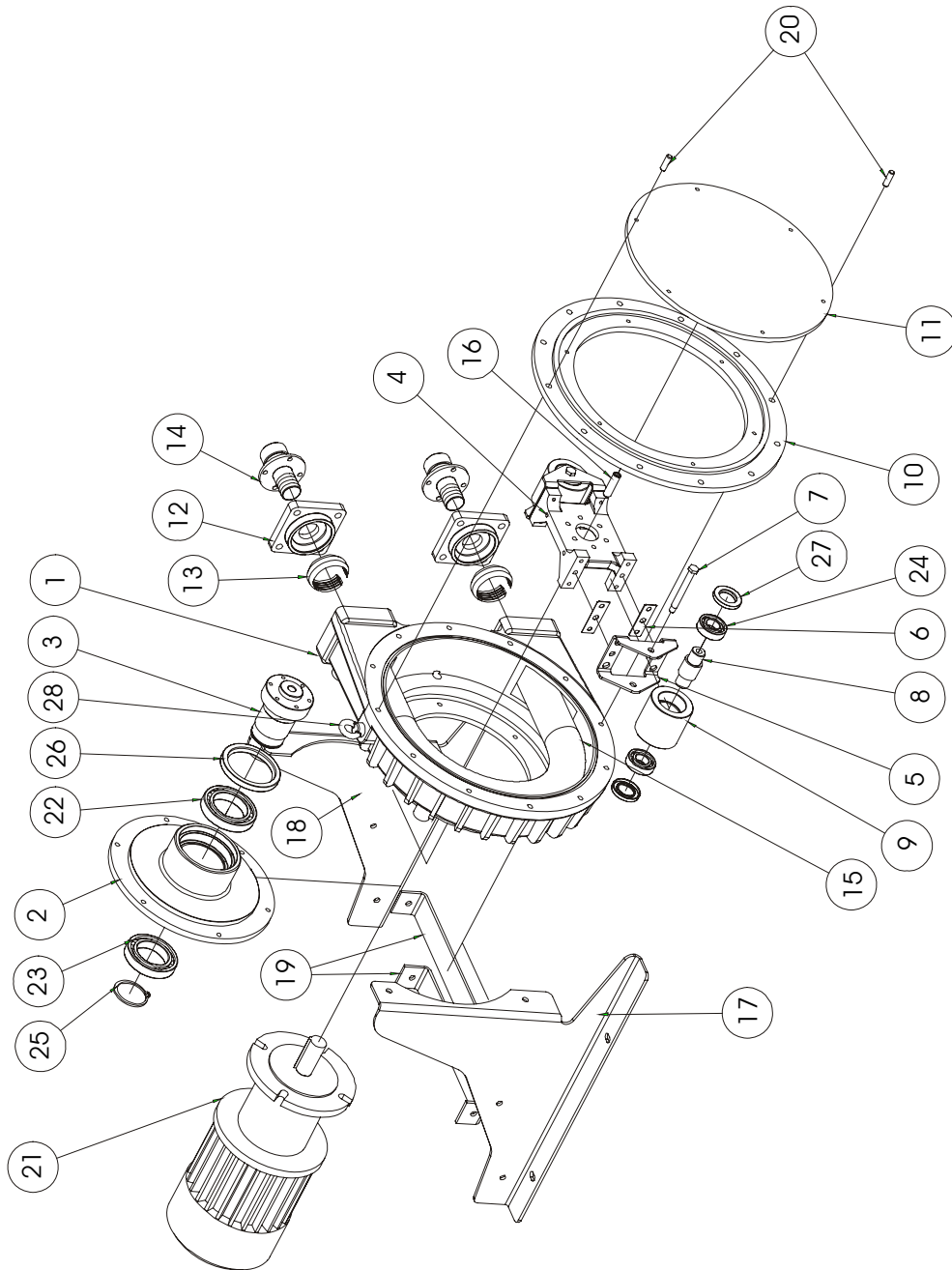

FMP-30/40

FMP-30

POS.	Description	Q	CODE		MATERIAL
1	Pump body	1	107.00.01		Cast Iron
2	Bearing housing	1	107.00.03		
3	Rotor shaft	1	107.00.04		Steel
4	Rotor	1	107.00.05		
5	Roller support	2	107.00.06		
6	Shim		107.00.07		Stainless
7	Shaft screw w/nut and washer	2	107.00.08	M10	
8	Roller shaft	2	107.00.09		
9	Roller	2	107.00.11		
10	Metallic cover	1	107.00.13		
11	Polycarbonate cover	1	107.00.14		
12	Press flange	2	107.00.15		Anodized Steel
13	Closing ring	2	107.00.16		Steel
14	Connection flange 1-1/4" ANSI	2	107.00.38		316SS
	Connection SS 1-1/4" MNPT	2	107.00.34		316SS
	Connection PolyPro 1-1/4" MNPT	2	107.00.44		Polypropylene
	Connection 1-1/2" TRI-CLAMP	2	107.00.36		316SS
15*	Natural Rubber Hose	1	107.00.18		
	Natural Rubber Hose (Food Grade)	1	107.00.19		
	Buna N Hose	1	107.00.20		
	Buna N Hose (Food Grade)	1	107.00.21		
	EPDM Hose	1	107.00.22		
16	Shaft cap	1	110.00.23		
17	Base left	1	100.01.24		
18	Base right	1	100.01.25		
19	Base middle	2	100.01.26		
20	Stud	2	106.00.27		
21	Driver	1			
22	Ball bearing - rear	1	100.01.28		
23	Ball bearing - front	1	100.01.29		
24	Ball bearing roller	4	107.00.30		
25	Ring for shaft	1	100.01.31		
26	Lip seal - housing	1	100.01.32		
27	Lip seal roller	4	107.00.33		
28	Eye bolt	1	106.00.40		
	Check Valve	1	110.00.53		
*	Food Grade Silicon Grease (16oz.)		106.00.41		
*	RECOMMENDED SPARE PARTS				REV 01.04.00

FMP-40

POS.	DESCRIPTION	Q	CODE		MATERIAL
1	Pump body	1	106.00.01		Cast Iron
2	Bearing housing	1	106.00.03		
3	Rotor shaft	1	106.00.04		Steel
4	Rotor	1	106.00.05		
5	Roller support	2	106.00.06		
6	Shim		106.00.07		Stainless
7	Shaft screw w/ nut and washer	2	106.00.08	M10	
8	Roller shaft	2	106.00.09		
9	Roller	2	106.00.11		
10	Metallic cover	1	106.00.13		
11	Polycarbonate cover	1	106.00.14		
12	Press flange	2	106.00.15		Anodized Steel
13	Closing ring	2	104.00.05		Steel
14	Connection flange 1-1/2" ANSI 150	2	106.00.38		316SS
	Connection SS 1-1/2" MNPT	2	106.00.34		316SS
	Connection PolyPro 1-1/2" MNPT	2	106.00.47		Polypropylene
	Connection 1-1/2" TRI-CLAMP	2	106.00.36		316SS
15*	Natural Rubber Hose	1	106.00.18		
	Natural Rubber Hose (Food Grade)	1	106.00.19		
	Buna N Hose	1	106.00.20		
	Buna N Hose (Food Grade)	1	106.00.21		
	EPDM Hose	1	106.00.22		
16	Shaft cap	1	110.00.23		
17	Base left	1	106.00.24		
18	Base right	1	106.00.25		
19	Base middle	2	106.00.26		
20	Stud	2	106.00.27		
21	Driver	1			
22	Ball bearing - rear	1	106.00.28		
23	Ball bearing - front	1	106.00.29		
24	Ball bearing roller	4	106.00.30		
25	Ring for shaft	1	106.00.31		
26	Lip seal - housing	1	106.00.32		
27	Lip seal roller	4	106.00.33		
28	Eye bolt	1			
	Check Valve	1	110.00.53		
*	Food Grade Silicon Grease (16oz.)		106.00.41		

* - RECOMMENDED SPARE PARTS

REV 01.04.00

WARRANTY

- PeriFlo warrants it's RBT and FMP pump equipment against all defects in materials, manufacturing and workmanship for two years from the date of shipment. This warranty does not include normal wearing items such as the hose or the lubricant since their life is highly dependent on the specific operating conditions of the application and installation.

- This warranty is valid as long as the equipment functions within the parameters indicated in the technical information card supplied with every pump or on subsequent changes authorized by PERIFLO, Inc.

- This warranty includes materials and labor only, and does not include transportation of materials to or from our warehouses in Loveland, Ohio. Transportation charges will be the responsibility of the customer.



CbN SERIES 3000

LUBRICATION

Series 3000 CbN gearing is shipped with one of the following synthetic lubricants per the table below and fitted with a magnetic drain. Each reducer is filled according to the mounting position specified when ordered. Refer to the unit nameplate and the chart to the left for the mounting position arrangement for your unit.

In the case of synthetic oil, the lubricant does not require changing, but it is recommended that proper oil level be checked periodically.

SYNTHETIC

NO BACKSTOP	
Manufacturer	-25° F to 125° F (-30° C to 50° C)
Cofran*	Sintogear 125
Mobil*	SHC* 629
Shell*	Omala* HD 150

WITH BACKSTOP	
Manufacturer	-25° F to 125° F (-30° C to 50° C)
Shell*	Omala* RL 100



- Never mix synthetic oil and mineral oil.
- Never use extreme pressure (EP) oil in a reducer with a backstop.

ACCEPTABLE MINERAL OIL LUBRICANTS

Manufacturer	-4° F to 14° F (-20° C to 10° C)	14° F to 122° F (-10° C to 50° C)				122° F and Above (50° C +)
		NO BACKSTOP		WITH BACKSTOP		
	ISO VG 68	ISO VG 100	ISO VG 150	ISO VG 220	ISO VG 150	ISO VG 320
Cofran*	Mecanep 68 GL	Cofraline Equitex 100	Mecanep 150	Equilux C2000 Super	Cofrapoid 80W 90	Mecanep 320
Mobil*	Mobil* Gear 626	Mobil* Gear 627	Mobil* Gear 629	Mobil* Gear 630	DTE* Extra Heavy	Mobil* Gear 632
Shell*	Omala* 68	Omala* 100	Omala* 150	Omala* 220	Morlina* 150	Omala* 320

OIL CAPACITIES (U.S. QUARTS)

Gear Frame	30	31			32			33			34			35		
		1	2	3	1	2	3	1	2	3	1	2	3	1	2	3
Reduction Stages	Any															
B3		0.37	0.63	0.63	0.26	1.00	1.00	0.95	1.69	1.69	2.09	3.49	3.49	3.38	5.49	5.49
B5		0.37	0.63	0.63	0.26	1.00	1.00	0.95	1.69	1.69	2.09	3.49	3.49	3.38	5.49	5.49
B6		0.53	1.00	1.30	0.63	1.85	2.43	1.48	3.49	4.62	3.25	7.40	7.40	6.34	13.21	13.21
B7		0.53	0.90	0.90	0.63	1.64	1.64	1.48	3.12	3.12	3.33	4.97	4.97	5.28	8.77	8.77
B8		0.74	1.16	1.16	1.06	2.38	2.38	2.01	4.76	4.76	4.42	7.08	7.08	7.71	13.95	13.95
B52	**	0.53	1.00	1.30	0.63	1.85	2.43	1.48	3.49	4.62	3.25	7.40	7.40	6.34	13.21	13.21
B53	**	0.74	1.16	1.16	1.06	2.38	2.38	2.01	4.76	4.76	4.42	7.08	7.08	7.71	13.95	13.95
B54	**	0.53	0.90	0.90	0.63	1.64	1.64	1.48	3.12	3.12	3.33	4.97	4.97	5.28	8.77	8.77
V1		0.58	1.22	1.22	0.69	2.38	2.38	2.22	4.76	4.76	4.05	7.93	7.93	6.13	15.53	15.53
V3		1.06	1.48	1.48	1.27	2.85	2.85	2.22	4.65	4.65	3.15	7.93	7.93	8.03	14.48	14.48
V5		0.58	1.22	1.22	0.69	2.38	2.38	2.22	4.76	4.76	4.05	7.93	7.93	6.13	15.53	15.53
V6		1.06	1.48	1.48	1.27	2.85	2.85	2.22	4.65	4.65	3.15	7.93	7.93	8.03	14.48	14.48

* The terms used in the above tables are the trade names, trademarks, and/or registered trademarks of the respective owners, are used herein for comparison or reference, and are not the property of, controlled by, or affiliated with Emerson Power Transmission Manufacturing, L.P.

** Refer to illustration below for fill level in all positions of size 30.

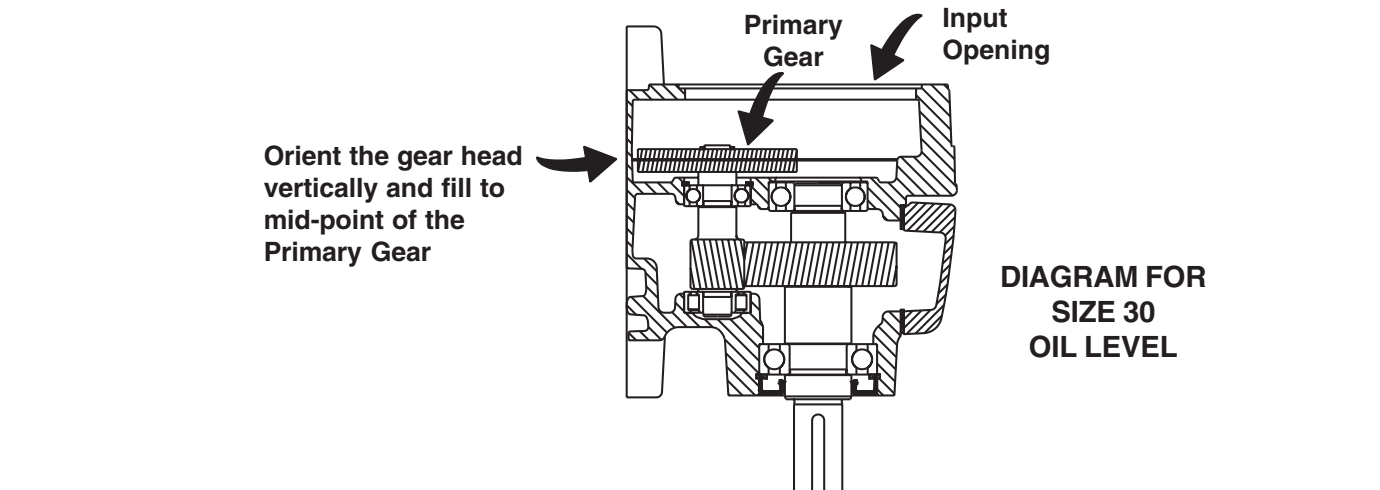

Disconnect all power before adjusting units.