

## **INSTRUCTION MANUAL**

This manual forms an integral part of the pump and must accompany it until its demolition. The series AMP peristaltic pump is a machine destined to work in industrial areas and as such the instruction manual must form part of the legislative dispositions and the applicable technical standards and does not substitute any installation standard or eventual additional standard.

### **GENERAL SAFETY WARNING**

Pumps are machines that can present dangers due to their operating under pressure and containing numerous moving parts.

- Improper use
- Removing the protections and/or disconnecting the protection device
- The lack of inspections and maintenance

### **CAN CAUSE SERIOUS DAMAGE OR INJURY**

The person in charge of safety should therefore guarantee that

- The pump is transported, installed, put in service, used, maintained and repaired by qualified personnel who should possess:

- Specific training and sufficient experience.
- Knowledge of the technical standards and applicable laws.
- Knowledge of the general national and local safety standards and also of installation.

Any work carried out on the electrical part of the pump should be authorised by the person responsible for safety. Given that the pump is destined to form part of an installation, it is the responsibility of whoever supervises the installation to guarantee absolute safety, adopting the necessary measures of additional protection.

## INDEX

---

	Page number
• Cover	01
• Index	02
• Transport and storage	03
• General safety standards	04
• General description	06
• Installation	07
• Roller pressure adjustment	08
• Check before start-up	09
• Maintenance	10
• Removing the hose – Disassembly	10
• Installing the hose – Assembly	10
• Problems, causes and solutions	11
• Diagram of components parts	12
• Spare parts code	13
• Model number convention	15
• Warranty	16

## **TRANSPORT AND STORAGE**

### **TRANSPORT**

- The pump is protected by a cardboard packaging.
- The packaging materials are recyclable.
- During transportation, the pump is in a resting position (the hose is not compressed)

### **STORAGE**

- The pump should be in a resting position. (The hose should not be compressed).
- Avoid areas open to inclement weather or excessive humidity.
- For storage periods of longer than 60 days, protect the coupling surfaces (clamps, reducers, and motors) with adequate anti-oxidant products.
- Pipe spares should be stored in a dry place away from direct light.

## SAFETY STANDARD



- Instructions of this manual that may compromise safety standards are identified by this symbol.



- Instructions of this manual that may compromise electrical safety are identified by this symbol.

WARNING!

- Instructions of this manual that may compromise the proper operation of the pump are identified with this symbol.



Do not start the pump without first having installed the front cover.

For any operation of the equipment, it is necessary to make certain that the pump is stopped and the electrical supply disconnected.



Changing the hose should be done with the pump stopped.



WARNING!

Do not exceed the nominal pressure, speed or temperature of the pump, or use the pump for applications other than that originally planned without first consulting the manufacturer.

### CHARACTERISTICS FOR CONTINUOUS SERVICE

Hose Material	Temp.Min. (°F)	Temp.Max. (°F)	Pressure Max. (psi)
Natural Rubber	-4	175	115
Buna	14	175	115
EPDM	14	175	115
NORPRENE	-4	265	30
PHARMED	-4	265	30
TYGON LFL		165	30

WARNING!

Cleaning the pump, including the hose, should be done with fluids compatible with the construction of the pump and hose, and in accordance with recommended maximum temperatures.

WARNING!

Do not start the pump without it being properly secured to the floor.



Do not attempt to carry out any maintenance operations or dismantle the pump without first making sure that the pipes are not under pressure and are empty or isolated by proper valving.



The start system of the motor should be provided with a direction inverter, stop-go button and emergency stop button (together with the pump), in such a way that the pump can be manipulated with total safety.



In the case of the hose becoming stuck during removal and/or installation it is recommended to reverse the direction of the pump, relubricate, and then repeat the operation.



Peristaltic pumps are positive displacement devices capable of generating high pressures. To prevent a possible overload of pressure, due to for example, the accidental closure of a valve. It is advisable to fit a safety device such as a safety valve or other pressure-limiting device in the discharge piping.



Check the direction of rotation of the pump, as it is reversible it could generate pressure in the suction and compromise the safety of the installation. The circulation of the fluid should be in the same direction as the turning direction of the pump as seen from the inspection plate situated on the front cover.



The durability of the hose may vary due to operating conditions, so the possibility of a rupture and subsequent leakage of the fluid should be anticipated. The (optional) hose leakage detection probe can be interlocked to stop the pump and/or actuate isolation valve and/or alarm.

## GENERAL DESCRIPTION

### PERISTALTIC PUMP

- **Construction of the pump.**

As shown in the figure below, the pump unit is a very simple design, robust and with very few moving parts.

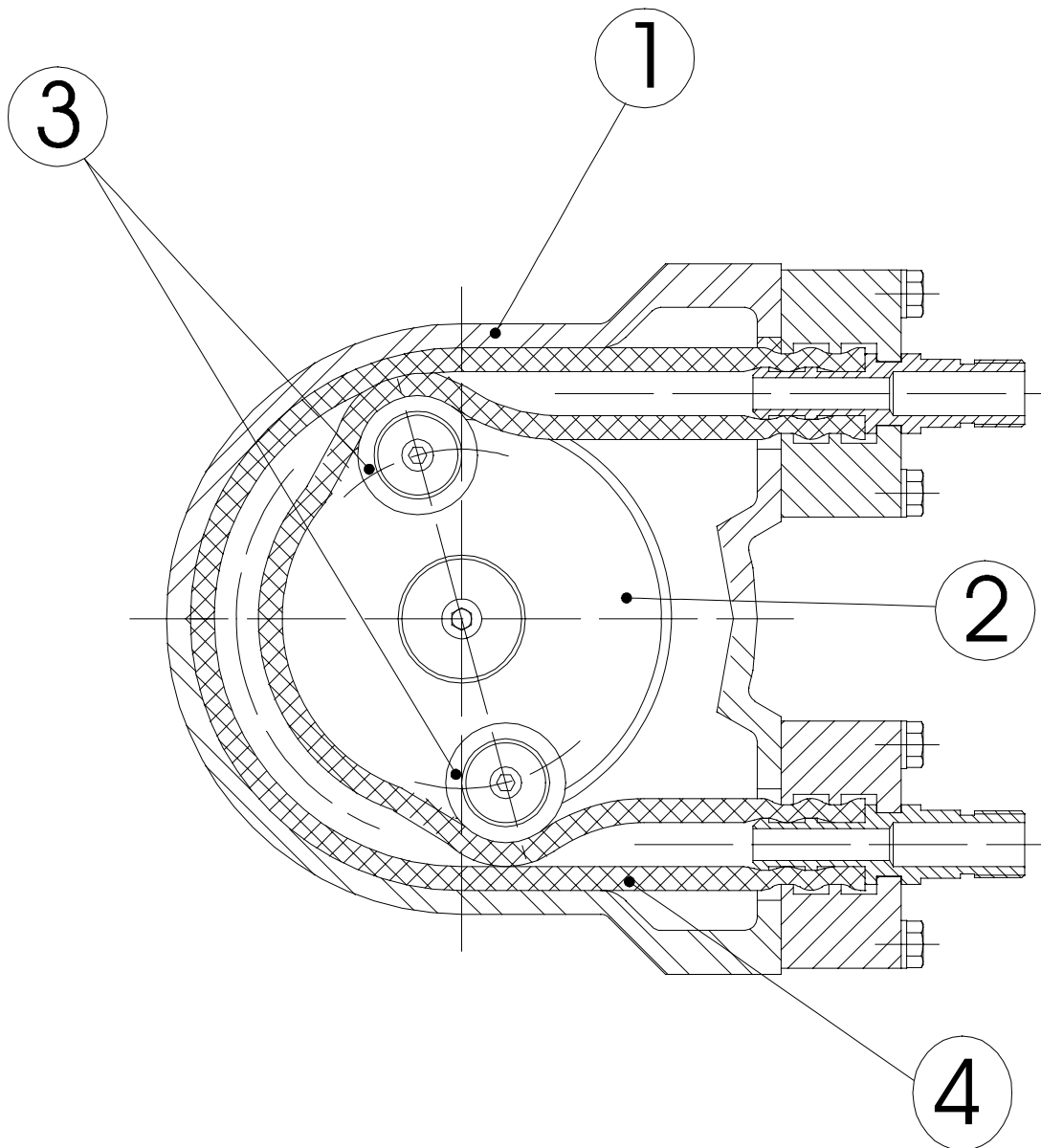

The outer casing (item 1) terminates with threaded connectors. Inside the casing are found the rotor (item 2) complete with two rollers (item 3). As the rotor turns, the rollers compress the reinforced hose/tube (item 4) generating a pumping action. A change in the direction of rotation will result in a change in direction of the pumped fluid.

## **INSTALLATION**

- Installation should normally be made in a well-ventilated area away from heat sources. If it is necessary to place the pump outside it should be provided with a cover to protect it from sunlight and inclement weather.
- The positioning of the pump should allow easy access for all kinds of maintenance operations.

### **Piping: Correct installation**

#### **Suction:**

- The pump should be located as near as possible to the supply of liquid so that the suction pipe is as short and straight as possible. The suction pipe should be perfectly airtight and made of suitable material so that it does not collapse due to the internal vacuum.
  - The minimum diameter should be similar to that of the hose/tube element.
  - With viscous fluids a larger diameter is recommended.  
(Consult manufacturer or distributor).
  - The pump has automatic suction and does not need an inlet valve.
- The pump is reversible, so the suction and discharge connections are interchangeable.  
(The pump is normally piped in a manner that best adapts to the physical installation)
- It is recommendable to use a flexible connection between the piping and the pump in order to avoid the transmission of vibration to the piping.

#### **Discharge:**

- To reduce power requirements, use the straightest and shortest piping possible. The diameter should be the same as the nominal diameter of the pump, except where precise calculations of piping losses have been performed.
  - With viscous fluids a larger diameter is needed.  
(Consult the manufacturer or distributor).
- Connect the fixed piping to the pump with a length of flexible pipe to facilitate maintenance, reduce vibrations and relieve piping stress on the pump. Fix the piping firmly.
- The discharge will pulse: To reduce the effect, it is advisable to install adequate pulsation dampeners.  
(See accessories.)

## ROLLER PRESSURE ADJUSTMENT

The peristaltic pump includes shims (Figure 6), that are used to adjust the exact pressing distance of the roller (figure 9).

The shims are installed from factory to work at the work conditions indicated (in function of the speed and the work pressure), and following the next tables:

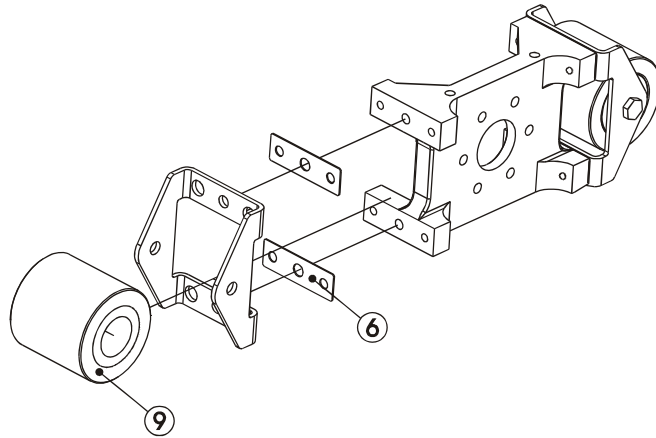

AMP-16C / Rubber hoses (Number of shims of 0,5 mm.)

rpm	0-19	20-39	40-59	60-79	80-99
Bar					
0,5	1	1	1	1	1
2,0	1	1	1	1	1
4,0	2	1	1	1	1
6,0	2	2	2		
8,0	3	3			

AMP-16C / Norprene tube (Number of shims of 0,5 mm.)

rpm	0-19	20-39	40-59	60-79	80-99
bar					
0,5	9	9	9	9	9
2,0	9	9	9	9	9

AMP-19C (Number of shims of 0,5 mm.)

rpm	0-19	20-39	40-59	60-79	80-99
bar					
0,5	5	5	5	5	5
2,0	5	5	5	5	5

## **CHECKS BEFORE SWITCHING ON THE PUMP**

- Check that the pumping equipment has not suffered any damage during transportation or storage, any damage should be notified to the supplier immediately.
  - Check that the supply voltage is suitable for the motor.
  - Make sure that the hose is suitable for the fluid to be pumped, that it will not be chemically affected and that the temperature of the fluid does not exceed that recommended.
- **Hose:** If the hose is in a resting position, then the pump has come from storage or transportation; now is the time to install the second roller. **Do not switch on the pump without the pump body cover being correctly installed.**

**Rotor:** Check that the roller shafts are correctly installed. For hose working pressures up to 60 psi (position 4), or thermoplastic tube (Norprene, Tygon, and Pharmed) operations up to 30 psi (position 2), the two mounting holes are marked with an indentation. The other two holes are unmarked and are suitable for hose working pressures from 60 to 115 psi (position 8).

**Lubrication:** Check that the hose/tube surface and the surface the rollers are correctly greased. Recommend clear Silicon grease (or other suitable lubricant) that will not damage rubber parts.

Check that the protectors of the moving parts are correctly assembled.

Check that the thermal protector corresponds with that of the values on the plate on the motor.

Check that the direction of rotation is the desired one. (rotation test).

Check that the optional electrical components are connected to the control panel and test that they function correctly.

Check that a proper pressure gauge is installed in the discharge. If the application involves a highly viscous fluid or long suction piping, it is recommended that a proper absolute-pressure gauge be installed in the suction.

Check predicted working conditions to verify that flow, pressure, temperature and motor power correspond to the project.

## **MAINTENANCE**

Any work carried out on the pump must be done when the pump is stationary and disconnected from the electrical supply.

### Lubrication

Check that the hose/tube and roller surfaces are correctly greased. Add lubricant as necessary.

Check that the lubricant level in the gear reducer and/or the variator is correct, and carry out periodic changes of lubricant according to the maintenance manual.

## **REMOVING THE HOSE – DISASSEMBLY** (refer to view on Page 14)

- Isolate the pump - all valves must be closed to prevent losses of the product.
- Disconnect the suction and discharge piping.
- Dismantle the suction/discharge hose/tube collars (item 11)
- Remove the front cover plate.
- Remove the rollers by first removing the roller that is not in contact with the hose/tube. Rotate the pump until the second rotor is not contacting the hose/tube and remove the second rotor.
- Remove the tube to be replaced and separate the inserts (item 10)

## **INSTALLING THE HOSE - ASSEMBLY**

- Clean the internal surfaces of the pump body. Lubricate the internal faces of the body of the pump where there could be friction with the hose. To carry out this operation correctly it is necessary to remove the front cover.

Recommend clear Silicon grease (or other suitable lubricant) that will not damage rubber parts.

- Inspect the rollers, checking that there is no damage to the pressure surface and that the bearings turn freely. If the pump is being set up for the first time, see paragraph Rotor in the section CHECKS BEFORE SWITCHING ON THE PUMP.
- Install inserts (item 10) into each end of the new hose/tube.
- Install the hose/tube into the pump body, lubricating the hose and the surface of the rollers with grease.
- Install the tightening collars that fasten the hose and its connections to the pump body.
- Install the rollers. (refer to removal procedure above)
- Install the front cover.
- Connect suction/discharge piping.

### 5.3. PROBLEMS, CAUSES AND SOLUTIONS

PROBLEM	POSSIBLE CAUSE	SOLUCIÓN
<b>Elevated temperature</b>	Hose with no lubricant Elevated temperature of product Poor or bad suction conditions  Excessive friction rollers to hose/tube  Excessive pumping speed	Use special lubricant PERIFLO Reduce pumping temperature Clear any obstructions Recalculate sections and lengths Check rollers shaft mounting  Reduce velocity of pump
<b>Reduction of capacity/pressure</b>	Suction or discharge valve closed. Hose insufficiently compressed  Rupture of the hose (the product leaks to the casing) Partial obstruction of suction piping Insufficient product amount in suction reservoir Insufficient diameter of suction piping Excessive length of suction pipe High viscosity of product  Entry of air via the suction connections High pulsation on suction	Open valves Check rollers shaft mounting  Replace drive hose Clean piping Fill or stop Increase pipe size/reduce pump speed Shorten suction piping Reduce viscosity Increase pipe size Confirm that the pump is suitable Tighten connections and accessories Mount antipulsation equipment Reconsider application (speed etc.)
<b>Vibrations in pump and piping</b>	The piping is not correctly fixed together Excessive pumping speed  Insufficient diameter of piping Baseplate of pump loose Elevated pulsation of pump	Refix piping/install flexible connections Reduce the speed of the pump  Increase pipe diameter Anchor the baseplate firmly Install pulsation dampening equipment in suction and/or discharge
<b>Short life of the hose</b>	Chemical attack  High speed of pump High pumping temperature High working pressure  Abnormal elevation of temperature Unsuitable lubricant Insufficient quantity of grease Cavitation of the pump	Confirm compatibility of the hose with the pumped fluid and the cleaning fluid Reduce speed of pump Reduce temperature of product Reduce speed of pump Increase discharge pipe size Check rollers shaft mounting/lubrication Use lubricant from PERIFLO Top up lubricant Reconsider suction conditions
<b>Stretching of the hose inside the pump</b>	Insufficient grease High suction pressures (>3 Bar) Hose full of sediment Brackets insufficiently tightened	Top up lubricant Reduce suction pressure Clean hose Retighten brackets
<b>The pump does not start</b>	Insufficient starter power Insufficient power from frequency converter  Blockage in the pump	Increase starter power Increase power Check that the voltage is adequate Do not drop below a frequency of 10Hz (confirm this point with the distributor) Starting up will require at least 10Hz. Check there are no obstructions in the pipe

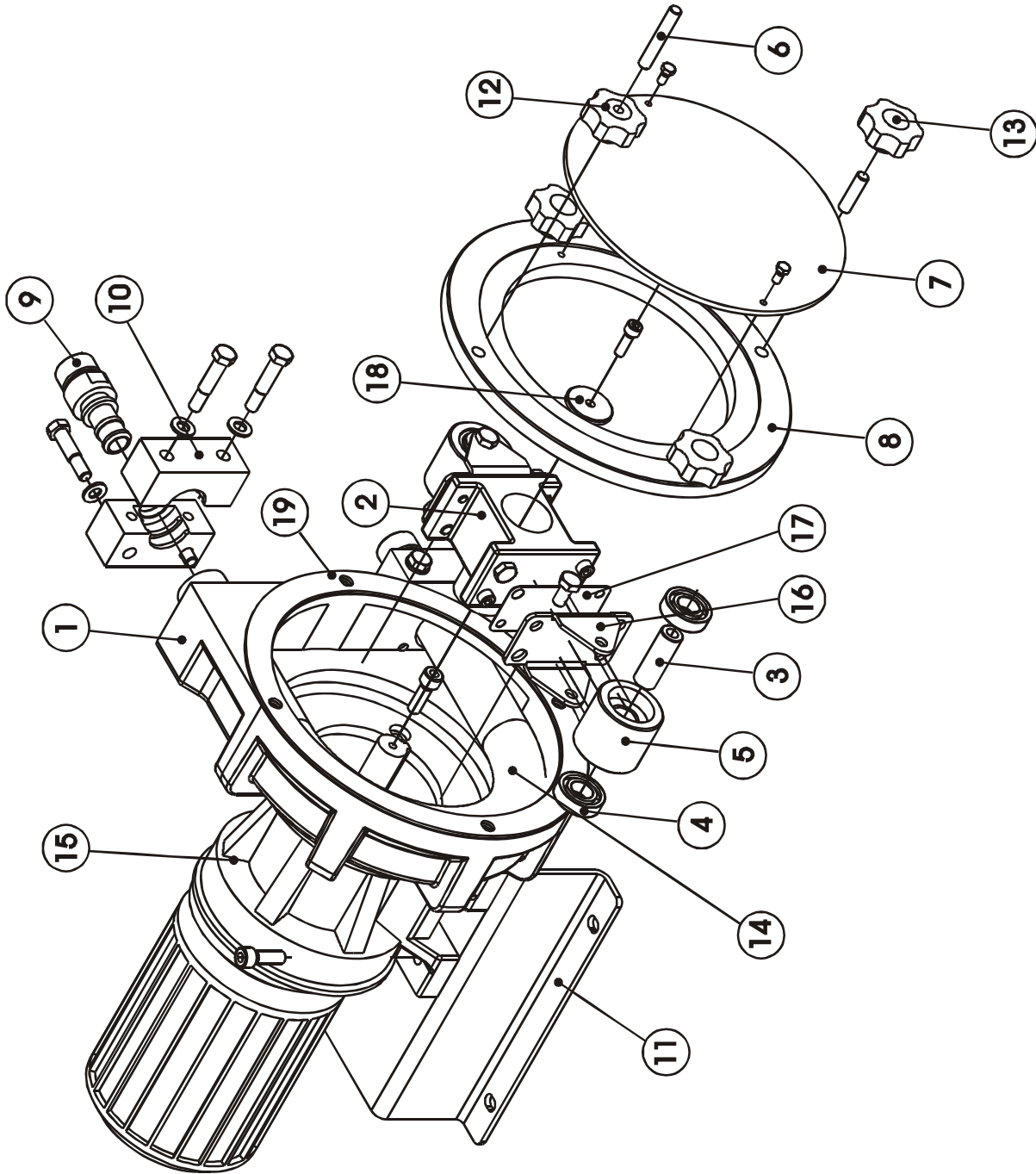

## AMP-16C

ITEM	DESCRIPTION	Q	CODE		MATERIAL
1	Pump casing	1	101.02.01		
2	Rotor	1	101.02.03		
3	Roller shaft	2	101.01.04		
4	Roller ball bearings	4	101.01.36		
5	Roller D45	2	105.01.07		
6	Long stud	1	102.00.07		
	Short stud	3	102.00.14		
7	Plastic cover	1	101.00.12		
8	Metallic cover	1	101.00.11		
9	Connection SS-NPT	2	101.00.16		
	Connection PP-NPT	2	101.00.17		
	Connection PVDF-NPT	2	101.00.18		
	Connection TRI-CLAMP	2	101.00.21		
10	Press flange hose	2	101.00.22		
	Press flange tube	2	101.00.23		
11	Base plate	1	101.00.24		
	Base plate S.S.	1	101.00.25		
12	Pommel	1	102.00.25		
13	Pommel blind	3	102.00.26		
14	Hose NR	1	101.00.26		
	Hose NBR	1	101.00.27		
	Hose NBR-A	1	101.00.32		
	Hose EPDM	1	101.00.28		
	Hose Norprene	1	101.00.30		
	Hose NR-A	1	101.00.31		
	Hose HYPALON	1	101.00.33		
	Hose TYGON	1	101.00.29		
15	Driver	1			
16	Roller Support	2	101.02.34		
17	Shim		101.02.35		
18	Rotor washer	1	101.02.13		
19	Cover gasket	1	102.99.21		

## AMP-19C

ITEM	DESCRIPTION	Q	CODE		MATERIAL
1	Pump casing	1	101.02.01		
2	Rotor	1	101.02.03		
3	Roller shaft	2	101.01.04		
4	Roller ball bearings	4	101.01.36		
5	Roller D45	2	105.01.07		
6	Long stud	1	102.00.07		
	Short stud	3	102.00.14		
7	Plastic cover	1	101.00.12		
8	Metallic cover	1	101.00.11		
9	connection SS-NPT	2	105.00.16		
	Connection PP-NPT	2	105.00.17		
	Connection PVDF-NPT	2	105.00.18		
	Connection TRI-CLAMP	2	105.00.21		
10	Press flange tube	2	101.00.22		
11	Base plate	1	101.00.24		
	Base plate S.S.	1	101.00.25		
12	Pommel	1	102.00.25		
13	Pommel blind	3	102.00.26		
14	Hose NORPRENE	1	105.00.27		
	Hose TYGON	1	105.00.26		
15	Driver	1			
16	Roller Support	2	101.02.34		
17	Shim		101.02.35		
18	Rotor washer	1	101.02.13		
19	Cover gasket	1	102.99.21		

## PERIFLO AMP SERIES - COMPLETE PUMP MODEL NUMBER

POS 1 - POS 2 - POS 3 - POS 4 - POS 5 - POS 6 - POS 7 - POS 8 - POS 9 - POS 10

### POS 1 - PUMP SERIES

AMP10  
AMP13  
AMP16  
AMP19

### POS 2 - HOSE/TUBE MATERIAL

NR - NATURAL RUBBER HOSE  
BN - BUNA HOSE  
EP - EPDM HOSE  
NF - NATURAL RUBBER HOSE (FD. GR.)  
BF - BUNA HOSE (FD. GR.)  
E1 - NORPRENE TUBE (FDA, 3A)  
PH - PHARMED TUBE (FDA, USP)  
TY - TYGON TUBE (AMP16 & 19 ONLY)

### POS 3 - DISCHARGE PRESSURE

2 - 30 PSI (TUBE)  
4 - 60 PSI (HOSE)  
8 - 116 PSI (HOSE)

### POS 4 - INSERTS

S - 316 STAINLESS NPT  
P - POLYPROPYLENE NPT  
K - PVDF (KYNAR) NPT  
T - TRI-CLAMP

### POS 5 - SUCTION/DISCHARGE ORIENTATION

A - RIGHT (standard)  
B - DOWN  
C - LEFT  
D - UP

### POS 6 - SPEED

000 - OTHER  
005 - 5 RPM  
006 - 6 RPM  
007 - 7 RPM  
009 - 9 RPM  
011 - 11 RPM  
013 - 13 RPM  
016 - 16 RPM

### POS 6 - SPEED

019 - 19 RPM  
024 - 24 RPM  
029 - 29 RPM  
036 - 36 RPM  
043 - 43 RPM  
054 - 54 RPM  
061 - 461 RPM  
068 - 68 RPM  
077 - 77 RPM  
086 - 86 RPM  
097 - 97 RPM  
114 - 114 RPM

### POS 7 - HORSEPOWER

X - NONE  
A - 0.25 HP  
B - 0.33 HP  
C - 0.50 HP  
D - 0.75 HP

### POS 8 - MOTOR ENCLOSURE

00 - NONE (NEMA 56C)  
T1 - TEFC (SINGLE PHASE)  
T3 - TEFC (THREE PHASE)  
TV - INVERTER DUTY (THREE PHASE)  
X1 - EXPLOSION PROOF (SINGLE PHASE)  
X3 - EXPLOSION PROOF (THREE PHASE)

### POS 9 - SPECIAL

3 - 3 ROLLERS

### POS 10 - ACCESSORIES

LD - LEAK DETECTOR  
VS - VARIABLE FREQUENCY DRIVE  
MV - MECHANICAL VARIATOR  
SC - SCADA SYSTEM

**WARRANTY**

- Periflo warrants its equipment against all defects in materials, manufacturing and workmanship for one year from the date of delivery. This warranty does not include normal wearing items such as the hose or lubricant since their life is highly dependent on the specific operating conditions of the application and installation.
- This warranty is valid as long as the equipment functions within the parameters indicated in the technical information card supplied with every pump or on subsequent changes authorised by PERIFLO.
- This warranty includes materials and labor only, and does not include transportation of materials to or from our warehouses in Loveland, Ohio, Transportation charges will be the responsibility of the customer.