

## **INSTRUCTION MANUAL**

This manual forms an integral part of the pump and must accompany it until its demolition. The series AMP peristaltic pump is a machine destined to work in industrial areas and as such the instruction manual must form part of the legislative dispositions and the applicable technical standards and does not substitute any installation standard or eventual additional standard.

### **GENERAL SAFETY WARNING**

Pumps are machines that can present dangers due to their operating under pressure and containing numerous moving parts.

- Improper use
- Removing the protections and/or disconnecting the protection device
- The lack of inspections and maintenance

### **CAN CAUSE SERIOUS DAMAGE OR INJURY**

The person in charge of safety should therefore guarantee that

- The pump is transported, installed, put in service, used, maintained and repaired by qualified personnel who should possess:

- Specific training and sufficient experience.
- Knowledge of the technical standards and applicable laws.
- Knowledge of the general national and local safety standards and also of installation.

Any work carried out on the electrical part of the pump should be authorized by the person responsible for safety. Given that the pump is destined to form part of an installation, it is the responsibility of whoever supervises the installation to guarantee absolute safety, adopting the necessary measures of additional protection.

---

## **INDEX**

Equipment Identification	01
Cover	02
Index	03
Transport, storage and elevation	04
General safety standards	05
General description	07
Installation	08
Roller pressure adjustment	09
Operating conditions	10
Performance curves	10
Checks before starting up the machine	11
Maintenance	12
Removing the hose – disassembly	12
Installing the hose – assembly	12
Problems, causes and solutions	13
Diagram of components parts	14
Spare parts list	15
Warranty	16

## **TRANSPORT, STORAGE and ELEVATION**

### **TRANSPORT**

- The pump is protected by a wood packaging.
- The packaging materials are recyclable.

## STORAGE

- Avoid areas open to inclement weather or excessive humidity.
- For storage periods of longer than 60 days, protect the coupling surfaces ( clamps, reducers, motors ) with adequate anti-oxidant products.
- Spare tubes should be stored in a dry place away from the direct light.

---

## GENERAL SAFETY STANDARDS



- Instructions of this manual that may compromise safety standards are identified by this symbol.



WARNING!

- Instructions of this manual that may compromise electrical safety are identified by this symbol.
- Instructions of this manual that may compromise the proper operation of the pump, are identified with this symbol.



Do not start the pump without first having installed the front cover.



For any operation of the equipment, it is necessary to make certain that the pump is stopped and the electrical supply disconnected.



Changing the hose should be done with the pump stopped.

WARNING!

Do not exceed the nominal design operating pressure, speed or temperature of the pump, or use the pump for applications other than that originally planned without first consulting the manufacturer.

WARNING!

Cleaning the pump, including the hose, should be done with fluids compatible with the construction of the pump and hose, and in accordance with recommended maximum temperatures.

WARNING!

Do not start the pump without it being properly secured to the floor.



Do not attempt to carry out any maintenance operations or dismantle the pump without first making sure that the pipes are not under pressure and are empty or isolated by proper valving.



The start system of the motor should be provided with a direction inverter, stop-go button and emergency stop button (together with the pump), in such a way that the pump can be manipulated with total safety.



In the case of the hose becoming stuck during removal and/or installation it is recommended to reverse the direction of the pump, relubricate, and then repeat the operation.



Peristaltic pumps are positive displacement devices capable of generating high pressures. To prevent a possible overload of pressure, due to for example, the accidental closure of a valve. It is advisable to fit a safety device such as a safety valve or other pressure limiting device in the discharge piping.



Check the direction of rotation of the pump, as it is reversible it could generate pressure in the suction and compromise the safety of the installation. The circulation of the fluid should be in the same direction as the turning direction of the pump as seen from the inspection plate situated on the front cover.



The durability of the hose may vary due to operating conditions, so the possibility of a rupture and subsequent leakage of the fluid should be anticipated. The (optional) hose leakage detection probe can be interlocked to stop the pump and/or actuate isolation valve and/or alarm.



For C.I.P. or S.I.P. applications, please consult the factory.

---

## GENERAL DESCRIPTION

---

### PERISTALTIC PUMP

- **Construction of the pump.**

As shown in the figure below, the pump unit is a very simple, robust design with very few moving parts.

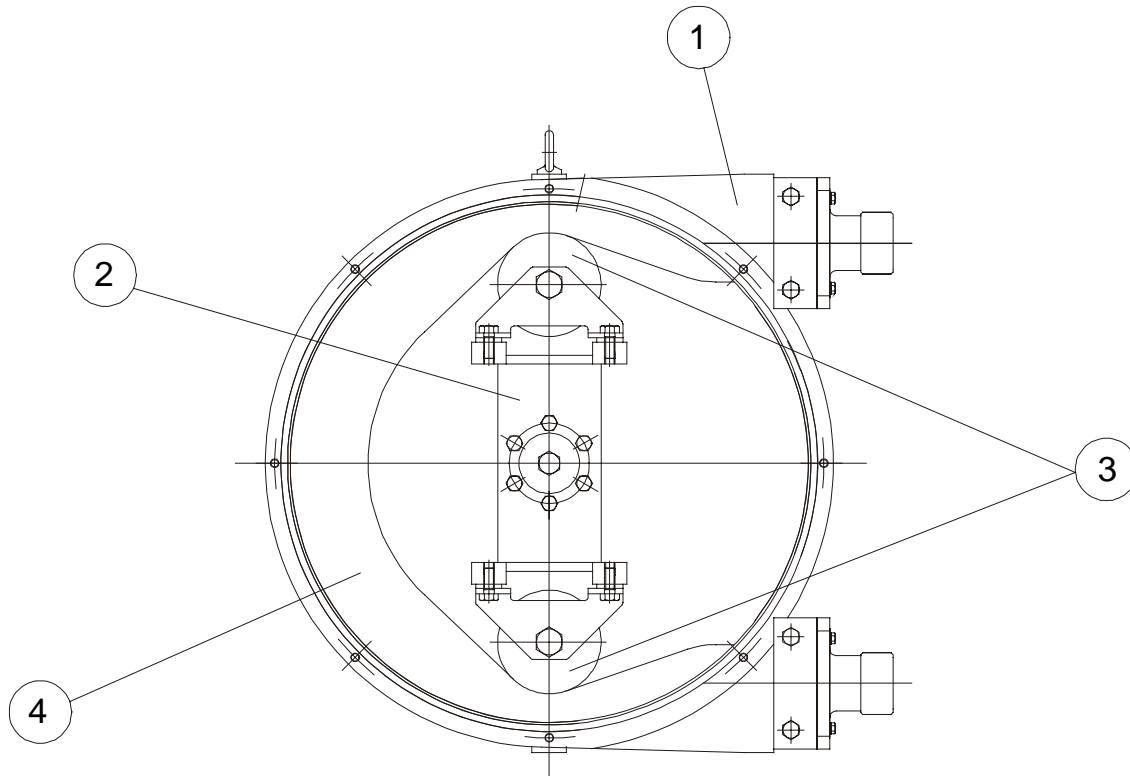

The outer casing (1) terminates with threaded connections. Inside the casing are found the rotor (2), complete with two rollers (3). As the rotor turns, the rollers compress the reinforced hose/tube (4), trapping a volume of fluid and forcing it out through the discharge. A change in the direction of rotation will give rise to a change in direction of the pumped fluid.

## INSTALLATION

- Installation should normally be made in a well ventilated area away from heat sources. If it is necessary to place the pump outside it should be provided with a cover to protect it from sunlight and inclement weather.
- The positioning of the pump should allow easy access for all kinds of maintenance operations.

**Piping: Correct installation****Suction:**

- The pump should be located as near as possible to the supply of liquid so that the suction pipe is as short and straight as possible. The suction pipe should be perfectly airtight and made of suitable material so that it does not collapse due to the internal vacuum.
  - The minimum diameter should be similar to that of the hose/tube element.
  - With viscous fluids a larger diameter is recommended.  
(Consult manufacturer or distributor).
  - The pump has automatic suction and does not need an inlet valve.
- The pump is reversible, so the suction and discharge connections are interchangeable.  
(The pump is normally piped in a manner that best adapts to the physical installation)
- It is recommendable to use a flexible connection between the piping and the pump in order to avoid the transmission of vibration to the piping.

**Discharge:**

- To reduce power requirements, use the straightest and shortest piping possible. The diameter should be the same as the nominal diameter of the pump, except where precise calculations of piping losses have been performed.
  - With viscous fluids a larger diameter is needed.  
(Consult the manufacturer or distributor).
- Connect the fixed piping to the pump with a length of flexible pipe to facilitate maintenance, reduce vibrations and relieve piping stress on the pump. Fix the piping firmly.
- The discharge will pulse: To reduce the effect, it is advisable to install adequate pulsation dampeners.  
(See accessories.)

---

**ROLLER ADJUSTMENT**

---

The AMP22 peristaltic pump, includes a shims ( item 6 ), that are used to adjust the compression of the hose/tube for design discharge pressure.

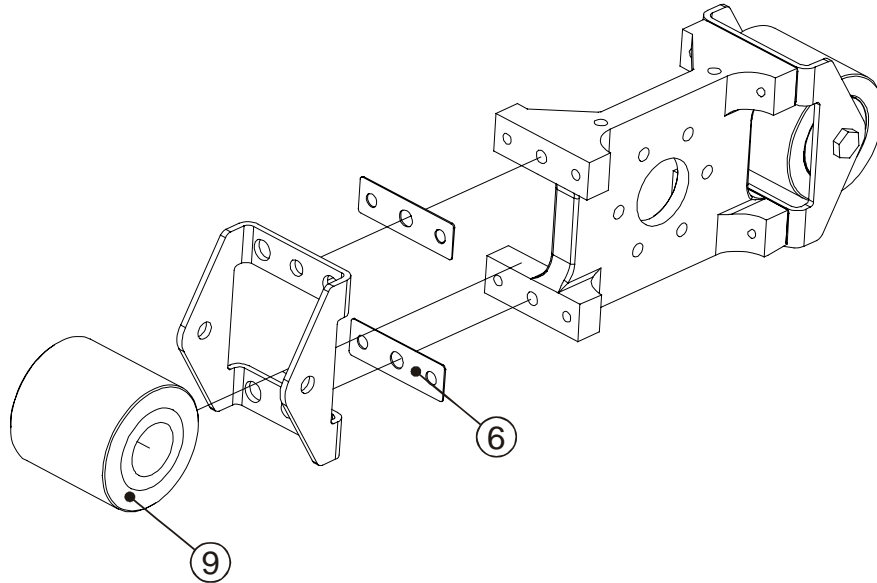

The shims are installed from factory to work at the operating conditions indicated in the Equipment Identification Record in the front of this manual, and according to the following table:

AMP-22 ( Number of shims of 0,5 mm. )

rpm	0-19	20-39	40-59	60-79	80-99
PSI					
7.5	2	2	1	1	1
30	2	2	2	2	2
60	3	3	2	2	2
90	3	3	3	--	--
115	4	3	--	--	--

## OPERATING CONDITIONS

Operating temperatures and pressures are limited by hose/tube construction as follows:

MATERIAL	TEMPERATURE MIN. (°F)	TEMPERATURE MAX. (°F)	AMBIENT TEMPERATURE MIN. (°F)	PRESSURE MAX. (PSI)
NR	-4	176	-40	115
NBR	14	176	-40	115
EPDM	14	176	-40	115
NR-A	14	176	-40	115
NBR-A	14	176	-40	115

## PERFORMANCE CURVES

### AMP-22

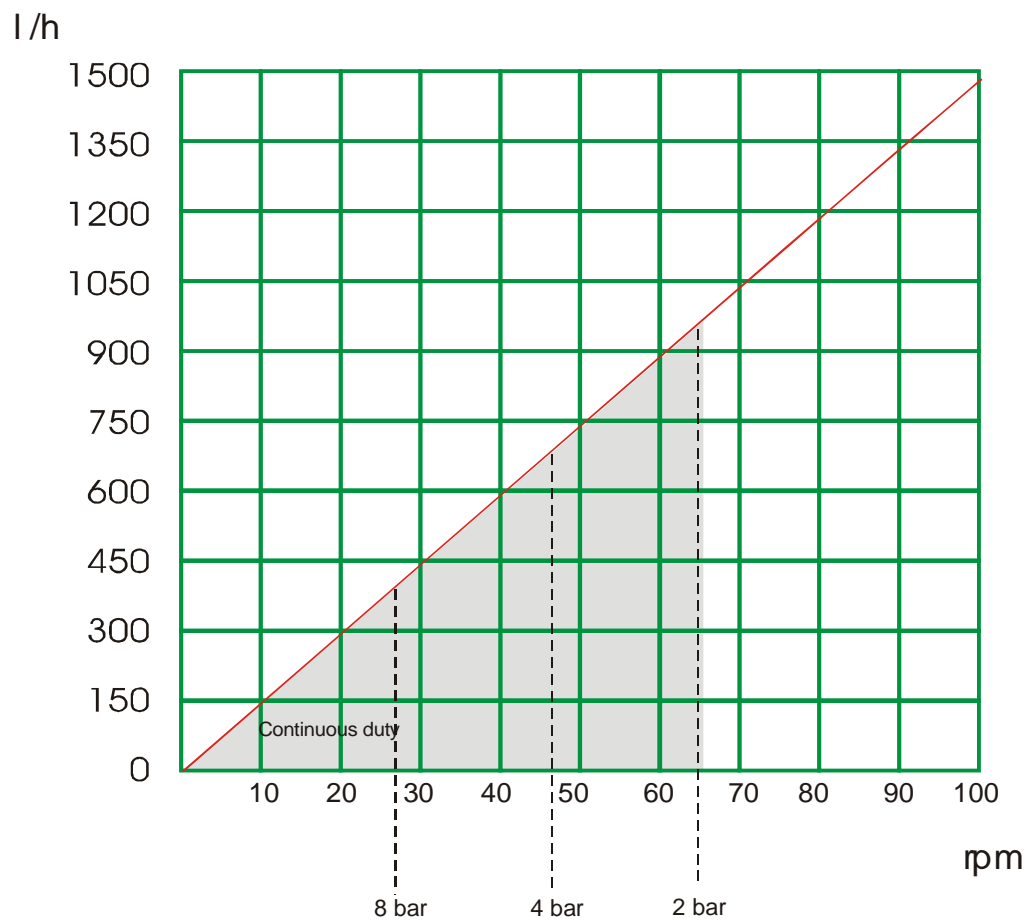

## CHECKS BEFORE SWITCHING ON THE PUMP

Check that the pumping equipment has not suffered any damage during transportation or storage, any

damage should be notified to the supplier immediately.

Check that the supply voltage is suitable for the drive and motor.

**Hose/Tube:** Make sure that the hose/tube is chemically compatible with the fluid to be pumped, that the operating temperature of the fluid does not exceed that recommended and that the operating pressure does not exceed that recommended for the hose/tube.

**Rollers:** If the roller supports are in a resting position, then the pump has come from storage or transportation; change the position to working position. **Do not switch on the pump without the pump body cover being correctly installed.**

**Rotor.** Check that the roller shafts are correctly installed. For hose working pressures up to 60 psi or tube working pressures up to 30 psi, rollers should be installed in the 4 bar position (marked by small holes). For hose operating pressures from 60 to 115 psi, rollers should be installed in the 8 bar position.

**Lubrication.** Check that the pumphead, the hose/tube and the rollers are liberally lubricated. The specially formulated food grade silicon grease can be obtained from PeriFlo Pumps or from the local authorized distributor.

Check that the protectors of the moving parts are correctly assembled.

Check that the thermal protector corresponds with the motor nameplate data.

Check for proper direction of rotation. (rotation test).

Check that the optional electrical components are connected to the control panel and test that they function correctly.

Check that a proper pressure gauge is installed in the discharge. If the application involves a highly viscous fluid or a long suction pipe, it is recommended that a proper absolute-pressure gauge be installed in the suction.

If excessive pulsation is anticipated or could be harmful to the system, the installation of a discharge pulsation dampening device is recommended.

Check in predicted working conditions that the values of flow, pressure and absorbed power of the motor correspond to the project.

---

## MAINTENANCE

---

Any work carried out on the pump must be done when the pump is stationary and disconnected from the electrical supply.

### Lubrication

Every 200 hours: Check that the rollers and the hose are properly greased. Add lubricant as necessary to maintain liberal lubrication. The specially formulated food grade silicon grease can be obtained from

PeriFlo Pumps or from the local authorized distributor.

Check that the lubricant level in the gear reducer and/or the variator are correct and carry out periodic changes of lubricant according to the manufacturer's maintenance manual.

## REMOVING OF HOSE - DISASSEMBLY

---

- Isolate the pump – all suction and discharge valves must be closed to prevent losses of product and limit personnel exposure.
- Disconnect the suction and discharge piping. (flexible connections are suggested)
- Remove the front cover.
- Remove the roller assembly that is not in contact with the hose/tube.
- Replace the cover and rotate the pump approximately 180° to release the other roller from the hose/tube.
- Separate the press flanges to free the hose/tube, and remove the hose/tube (along with the inserts if desired).

## INSTALLING THE HOSE - ASSEMBLY

---

- Clean the internal surfaces of the pump body. Lubricate the internal faces of the body of the pump where there could be friction with the hose.
- Inspect the rollers, checking for any damage to the pressure surface and condition of the roller bearings. If the pump is being set up for the first time, see paragraph Rotor in the section CHECKS BEFORE SWITCHING ON THE PUMP.
- Insert the connections in each hose end.
- Install the hose in the pump body, and liberally lubricate the hose and the rollers with food grade silicon grease. The specially formulated food grade silicon grease can be obtained from PeriFlo Pumps or from the local authorized distributor.
- Mount the tightening collars that fasten the hose and its connections to the pump body.
- Replace the roller assembly.
- Install the front cover.
- Reconnect the suction/discharge piping.

## PROBLEMS, CAUSES AND SOLUTIONS

---

PROBLEM	POSSIBLE CAUSE	SOLUCIÓN
---------	----------------	----------

<b>Elevated temperature</b>	Hose with no lubricant Elevated temperature of product Poor or bad suction conditions  Rollers not turning properly  Excessive pumping speed	Use special lubricant (PeriFlo) Reduce pumping temperature Clear any obstructions Recalculate sections and lengths Check roller to shaft mounting  Reduce velocity of pump
<b>Reduction of capacity/pressure</b>	Suction or discharge valve closed. Hose insufficiently compressed  Rupture of the hose (the product leaks to the casing) Partial obstruction of suction piping Insufficient product amount in suction reservoir Insufficient diameter of suction piping Excessive length of suction pipe High viscosity of product  Entry of air via the suction connections High pulsation on suction	Open valves as necessary Check roller/shaft positioning  Replace drive hose Clean piping Fill or stop Increase pipe size/reduce pump speed Shorten suction piping Reduce viscosity Increase suction pipe size Confirm that the pump is suitable Tighten connections and accessories Install pulsation dampener Reconsider application (speed etc.)
<b>Vibrations in pump and piping</b>	The piping is not correctly fitted together Excessive pumping speed  Insufficient diameter of piping Baseplate of pump loose Elevated pulsation of pump	Refit piping Reduce the speed of the pump  Increase pipe diameter Anchor the baseplate firmly Mount suction or discharge pulsation dampening equipment
<b>Short life of the hose</b>	Chemical attack  High speed of pump High pumping temperature High working pressure  Abnormal elevation of temperature Unsuitable lubricant Insufficient quantity of grease Cavitation Pump Cavitation of the pump	Confirm compatibility of the hose with the pumped fluid and any cleaning fluids Reduce speed of pump Reduce temperature of product Reduce speed of pump Increase diameter of discharge pipe Check rollers shaft mounting Use lubricant PERIFLO Top off lubricant Reconsider suction conditions
<b>Stretching of the hose inside the pump</b>	Insufficient grease High suction pressures (>3 Bar) Hose full of sediment Brackets insufficiently tightened	Top off lubricant Reduce suction pressure Clean hose Retighten brackets
<b>The pump does not start</b>	Insufficient starter power Insufficient power from frequency converter  Blockage in the pump	Increase starter power Increase power Check that the voltage is adequate Do not drop below a frequency of 10Hz (confirm this point with the distributor) Start-up will occur at least 10Hz. Check there are no obstructions in the pipe

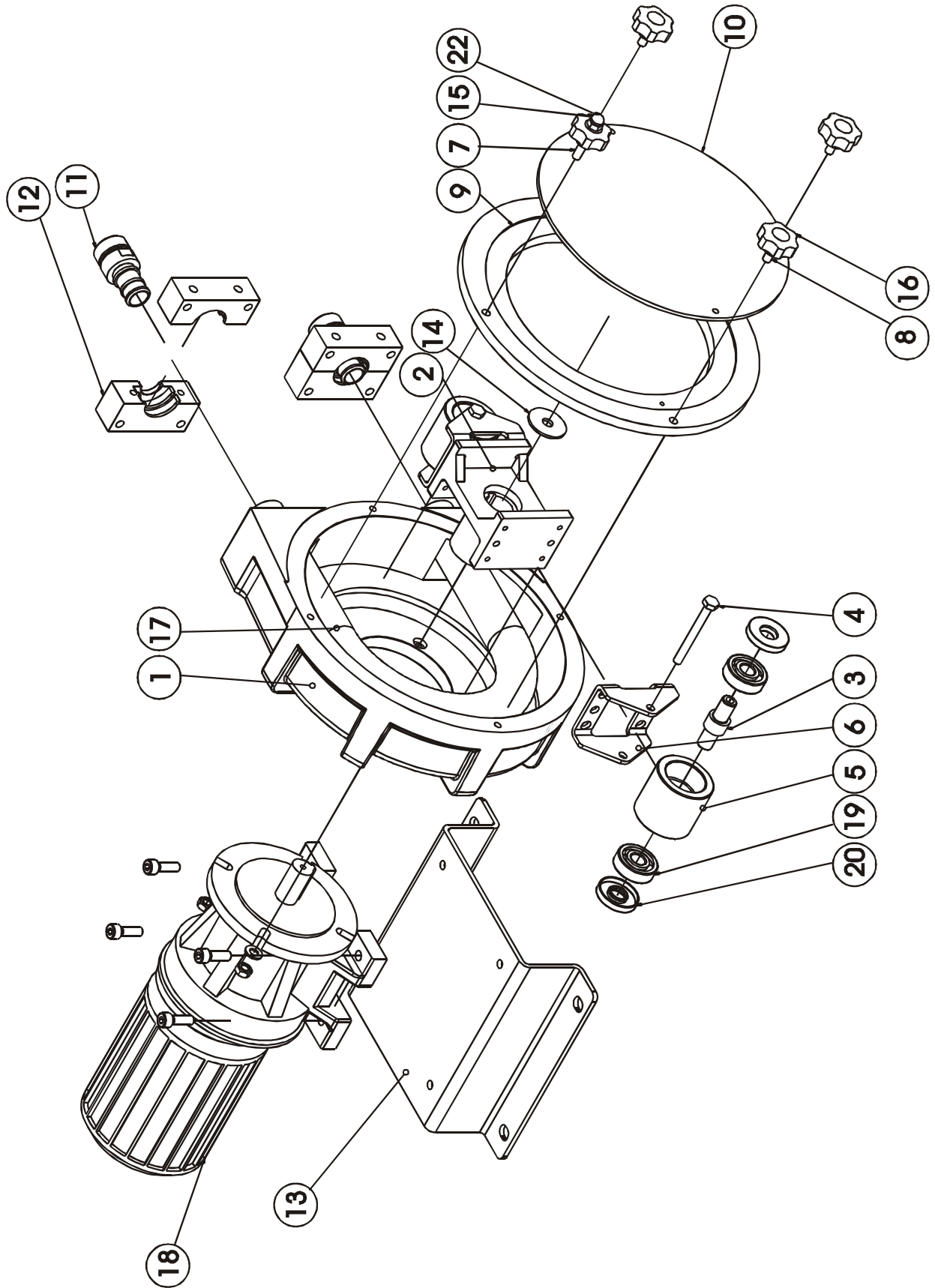

ITEM	DESCRIPTION	Q	CODE		MATERIAL
1	Pump body	1	113.00.01		Epoxy Coated AL
2	Rotor	1	113.00.02		Anodized Steel
3	Shaft roller	2	113.00.03		
4	Screw roller shaft	2	113.00.04		
5	Roller standard	2	113.00.05		
	Roller for thermoplastic hose	2	113.00.06		
6	Roller support	2	113.00.07		
7	Stud long	1	102.00.07		
8	Stud short	3	102.00.14		
9	Cover metallic part	1	113.00.08		Epoxy Coated Steel
10	Cover plastic part	1	113.00.09		Polycarbonate
11	Connection INOX-NPT	2	113.00.13		
	Connection PP-NPT	2	113.00.14		
	Connection PVDF-NPT	2	113.00.15		
	Connection TRI-CLAMP	2	113.00.18		
12	Press flange (standard hose)	2	113.00.19		
	Press flange (thermoplastic tube)	2	113.00.20		
13	Baseplate	1	113.00.21		
	Baseplate S.S.	1	113.00.22		
14	Washer rotor	1	113.00.23		
15	Press pommel	1	102.00.25		
16	Press pommel blind	3	102.00.26		
17 *	Hose NR	1	113.00.24		
	Hose NBR	1	113.00.25		
	Hose NBR-A	1	113.00.26		
	Hose EPDM	1	113.00.27		
	Hose Norprene	1	113.00.28		
	Hose NR-A	1	113.00.29		
	Hose HYPALON	1	113.00.30		
18	Driver	1			
19	Ball bearing roller	4	113.00.31		
20	Lip seal roller	4	113.00.32		
*	Grease Lube (Food Grade)	1	102.99.12	4 oz.	Silicon

**\* Recommended Spare Parts**

**WARRANTY**

- PeriFlo warrants its AMP Series equipment against all defects in materials, manufacturing and workmanship for one year from the date of delivery. This warranty does not include normal wearing items such as the hose or lubricant since their life is highly dependent on the specific operating conditions of the application and installation.
- This warranty is valid as long as the equipment functions within the parameters indicated in the technical information card supplied with every pump or on subsequent changes authorized by PERIFLO.
- This warranty includes materials and labor only, and does not include transportation of materials to or from our warehouses in Loveland, Ohio, Transportation charges will be the responsibility of the customer.