

PERIFLO

Industrial Peristaltic Pump

AMP-19 Model

Dimensions (Inches)

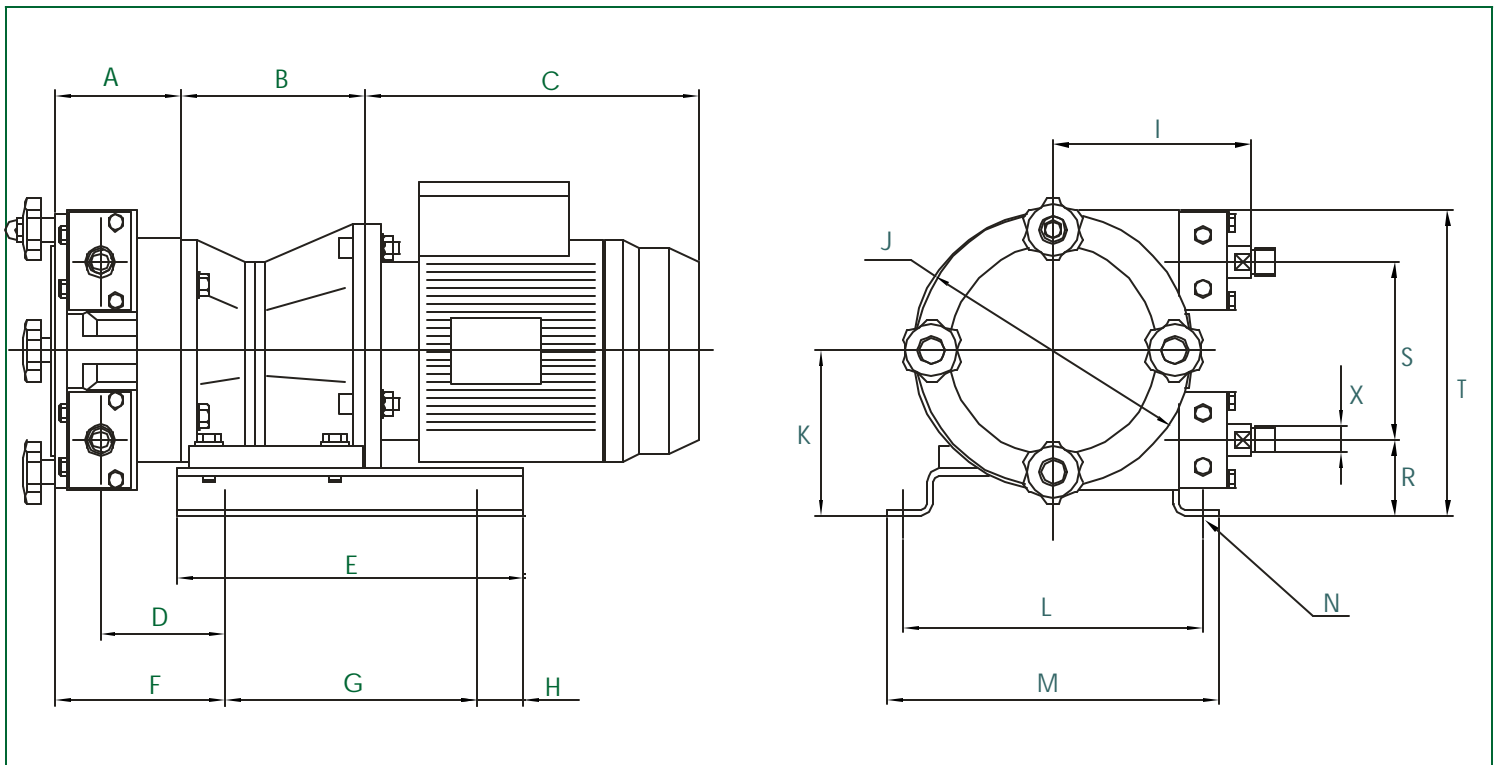

A	B	C	D	E	F	G	H	I	J	K	L	M	N	R	S	T	X
4.72	*	*	3.66	8.66	5.12	6.30	1.18	6.10	9.45	5.71	7.48	8.27	0.35	2.36	6.69	10.43	3/4" NPT

	ApproxWgt
Pumpw/Gear-Reducer&¼HPmotor	61 lbs
Pumpw/Gear-Reducer&1/3HPmotor	63 lbs
Pumpw/Gear-Reducer&½HPmotor	68 lbs

* Toconfirmaccordingtodrivetvneandpower